



Always the Right Solution™

Section:
L and J FRAME PUMPS
Page: 1
Date: December 1, 1997

OPERATION – ASSEMBLY INSTRUCTIONS AND PARTS LIST FOR “L2” DRIVE END (FRAME SIZES 1L2, 2L2, 3L2, 2M1, 3M1, 6M1)

GENERAL

The Moyno® Pump is one of the most versatile pumps available. It has been proven in thousands of applications over the past 50 years. It is backed by the experience gained over these years, both in application and manufacturing expertise.

The Moyno progressing cavity pump is a single-screw rotary pump. The pumping action is created by the single helical rotor rolling eccentrically in the double threaded helix of the stator. In its revolution, the rotor forms in conjunction with the stator a series of sealed cavities 180 degrees apart. As the rotor turns, the cavities progress from the suction to the discharge. As one cavity diminishes, the opposing cavity is increasing at exactly the same rate. Thus, the sum of the two discharges is a constant volume. The result is a pulsation-less positive displacement flow with no valves.

NAMEPLATE DATA

The Moyno Pump nameplate, located on the bearing housing, carries the serial number, frame size, and type designation. All are extremely important and must be used when ordering spare parts.

Record the nameplate data of your pump in the spaces provided in the heading of Page 112.

Moyno Pumps are identified by Frame and Type. Pump Frame is essentially an indication of size. It consists of a number, a letter, and a number (i.e. 2L2). The first number indicates the number of stages in the pumping elements. The letter indicates the model. The final number indicates the size of the rotor-stator pumping elements. A frame 2L2 pump, therefore, has two stages of size 2 pumping elements.

The “L” in the frame size indicates a standard relationship between the housing, bearings, and drive shaft and the size of the pumping elements. Many variations may be made by adapting smaller element sizes to a larger drive end size. This may be necessary due to the severity of a specific pumping application. In cases where the drive end (housing, bearings, and drive shaft) is one size larger than the element size normally used, the pump is referred to as an “M” frame pump (i.e. 2M1). Thus, a frame 3L2 and 2M1 would use a common drive end.

Type designation is a series of letters which identify the “Materials of Construction” in component groups of parts. The usual type designation will consist of three letters.

The first letter identifies the material of the suction housing casting or the body casting where the bearing housing is a part of the suction housing.

The second letter indicates the material used in the drive shaft, pins, connecting rod, rotor, and other minor metallic parts in contact with the material being pumped.

The third letter determines the material of the stator. It identifies only the stator material and not that of the tube in which the stator is placed.

A typical type designation such as CDQ would result in the following:

- C = Cast Iron Suction Housing
- D = Hardened Steel Internals including drive shaft, pins, connecting rod, rotor, and other minor metallic parts in contact with the material being pumped
- Q = Nitrile Synthetic Rubber Stator (70 durometer)

The following letters identify the actual materials that are used in standard construction:

- | | |
|---------------------------|-----------------------------------|
| B - EPDM | Q - Nitrile (70 durometer) |
| C - Cast Iron | R - Natural Rubber (55 durometer) |
| D - Hardened Steel | S - Stainless Steel, type #316 |
| F - Fluoroelastomer | T - Teflon (glass impregnated) |
| G - Stainless Steel, #416 | |

Also included on the nameplate is the three-character trim code designation. This only appears on pumps which have semi-standard or special construction. The first letter identifies sealing variations, the second character identifies internal variations, and the third letter identifies rotor variations.

On page 5 of this manual are variations available for modifying pumps to meet specialized pumping conditions. If the trim code of your pump is other than “AAA”, contact your nearest Moyno representative for clarification. Do not use any variation unless you have determined that it is compatible with your application.

Do not order by Reference Number. Use Part Number on page 112.

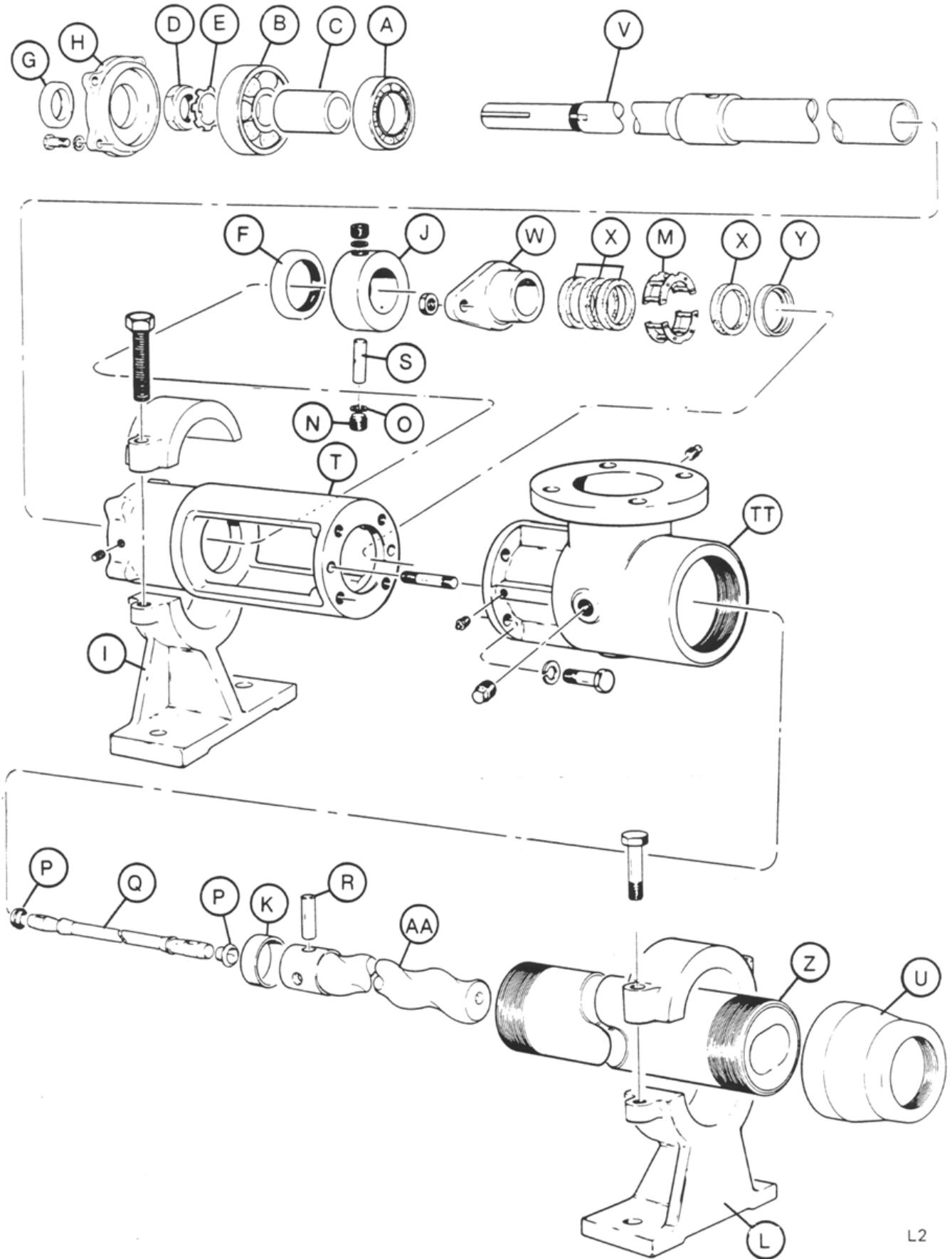

NAMEPLATE DATA

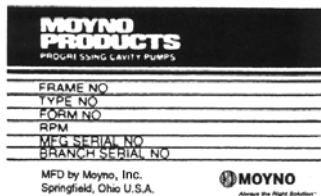

“L2” DRIVE END PARTS
TYPE DESIGNATIONS

Select type column corresponding to type designation at left.
Order by part number Refer to frame size to select proper rotor and stator.

REF. NO.	DESCRIPTION	CDQ	CDD	CSQ	CSD	SSQ	SSD
		CDR	CDG	CSR	CSG	SSR	SSG
		CDB	CDT	CSB	CST	SSB	SST
		CDF		CSF		SSF	
NO.		Part No.	Part No.	Part No.	Part No.	Part No.	Part No.
A.	Ball Bearing (Radial)	A02291	A02291	A02291	A02291	A02291	A02291
B.	Ball Bearing (Thrust)	A02301	A02301	A02301	A02301	A02301	A02301
C.	Bearing Spacer	A02331	A02331	A02331	A02331	A02331	A02331
D.	Bearing Lock Nut	A02581	A02581	A02581	A02581	A02581	A02581
E.	Bearing Lock Washer	A02591	A02591	A02591	A02591	A02591	A02591
F.	Grease Seal (Radial)	A02611	A02611	A02611	A02611	A02611	A02611
G.	Grease Seal (Thrust)	A02621	A02621	A02621	A02621	A02621	A02621
	Bearing Kit**	K02291	K02291	K02291	K02291	K02291	K02291
H.	Bearing Cover Plate	A02341	A02341	A02341	A02341	A02341	A02341
I.	Body Support	A02371	A02371	A02371	A02371	A02371	A02371
J.	Shaft Collar	A02491	A02491	A02491	A02491	A02491	A02491
K.	Pin Retainer	A02501	A02501	A02501	A02501	A02501	A02501
L.	Stator Support	A02381	A02382	A02381	A02382	A02381	A02382
M.	Lantern Ring	A02571	A02571	A02571	A02571	A02571	A02571
N.	Drive Pin Retaining Nut	A02541	A02541	A02541	A02541	A02541	A02541
O.	Retaining Nut Washer	A02731	A02731	A02731	A02731	A02731	A02731
P.	Connection Rod Washer	A02531	Not Rq.	A02531	Not Rq.	A02531	Not Rq.
Q.	Connecting Rod	B0225D	B0225D	B0225S	B0225S	B0225S	B0225S
R.	Rotor Pin	B0245D	B0245D	B0245S	B0245S	B0245S	B0245S
S.	Shaft Pin	B0246S	B0246S	B0246S	B0246S	B0246S	B0246S
	Connecting Rod Kit***	K0225D	K0225D	K0225S	K0225S	K0225S	K0225S
T.	Bearing Housing	A02051	A02051	A02051	A02051	A02051	A02051
TT.	Suction Housing	B02021	B02022	B02021	B02022	B02026	B02027
T.	Pump Body	B02011	B02012	B02011	B02012	B02016	B02017
U.	Reducer	B02091	B02092	B02091	B02092	B02096	B02097
V.	Drive Shaft +	B02261	B02261	B02266	B02266	B02266	B02266
W.	Packing Gland	B0241D	B0241D	B0241S	B0241S	B0241S	B0241S
X.	Packing +	B02421	B02421	B02425	B02425	B02425	B02425
Y.	Packing Washer	B0265D	B0265D	B0265S	B0265S	B0265S	B0265S
Z.	Stator Frame 2M1	C4201*	C4201*	C4201*	C4201*	C5201*	C5201*
	Frame 3M1	C4301*	C4301*	C4301*	C4301*	C5301*	C5301*
	Frame 6M1	C4601*	C4601*	C4601*	C4601*	C5601*	C5601*
	Frame 1L2	C4102*	C4102*	C4102*	C4102*	C5102*	C5102*
	Frame 2L2	C4202*	C4202*	C4202*	C4202*	C5202*	C5202*
	Frame 3L2	C4302*	C4302*	C4302*	C4302*	C5302*	C5302*
AA.	Rotors Frame 2M1 +	C72011	C72011	C82011	C82011	C82011	C82011
	Frame 3M1 +	C73011	C73011	C83011	C83011	C83011	C83011
	Frame 6M1 +	C76011	C76011	C86011	C86011	C86011	C86011
	Frame 1L2 +	C71021	C71021	C81021	C81021	C81021	C81021
	Frame 2L2 +	C72021	C72021	C82021	C82021	C82021	C82021
	Frame 3L2 +	C73021	C73021	C83021	C83021	C83021	C83021

* ADD THIRD LETTER OF TYPE DESIGNATION TO COMPLETE PART NUMBER.
EX: TYPE CDQ PUMP – ADD Q TO BASIC NUMBER OF STATOR

** Bearing Kit includes Items A thru G
*** Connecting Rod Kit includes items N thru S.
+ see pages 5 – 6 for variations

INSTRUCTIONS FOR DISASSEMBLY AND ASSEMBLY

Frames 1L2, 2L2, 3L2, 2M1, 3M1, 6M1

Disassembly Procedure

1. Disconnect the power source.
2. Close the suction and discharge valves to isolate the pump from the line.
3. Turn off flush water to packing or rotary seal if used.
4. Remove drain plug in pump body to drain away any fluid remaining in pump.
5. Place a support block under pump body in area of drain plug. Wooden blocks are sufficient. The purpose is to prevent undue stress on pump support when pump is disassembled.
6. Disconnect piping from stator end of pump.
7. **Stator Removal** - With pipe wrench or strap wrench remove discharge reducer (U). Remove cap of stator support and with strap wrench or pipe wrench, unscrew the stator (Z) from the suction housing. Pull Stator off the rotor.
8. **Rotor Removal** . The rotor (AA) is removed with the connecting rod (Q) and rotor pin (S) as a unit. Removal of the unit is accomplished by removing the two drive pin retaining nuts (N) located in the shaft collar (J). This step reveals the shaft drive pin (R) which is removed by driving the pin from the drive shaft (V) with a small punch or drift pin. Slide the shaft collar toward the packing gland (W) and remove the retaining screw washers (O) from each side of the drive shaft. The rotor and connecting rod can now be removed by pulling them from the pump. To disassemble, clamp the connecting rod (Q) by its mid-section in a vise and with a drift pin, drive the pin retainer (K) from the head of the rotor. The rotor pin (S) can now be removed from the rotor freeing the connecting rod. Remove the connecting rod washers (P) if present.
9. To remove packing (X), remove nuts holding packing gland (W). Slip packing gland from studs, remove packing rings, lantern ring (M), and remaining packing rings. Packing rings can be removed with a standard packing puller. Note: If step 10 is to be performed, it should precede step 9 as packing can then be removed by freeing packing gland and driving packing, lantern ring, and packing washer (Y) from housing using a small rod. Rod should enter where stator screws into pump body. Place rod on packing washer and tap. Entire set should easily exit from opposite end of stuffing box.
10. **Drive Shaft & Bearing Removal** - With rotor removed it is now possible to remove the drive shaft and bearings as a sub-assembly. Remove the four cap screws holding the bearing cover plate (H) and slip from shaft. Insert a bar or rod into the hollow end of drive shaft (V) where it enters the suction cavity. By tapping on the rod the entire assembly will be forced from the pump body.

To disassemble, remove bearing lock nut (D) and bearing lock washer (E). Using an arbor press remove radial bearing (A), bearing spacer (C), and thrust bearing (B). Apply pressure to inner race only. When replacing drive shaft and/or bearings, it is recommended that both grease seals be replaced. Grease seals are pressed into the bearing housing and bearing cover plate.

Assembly Procedure

Moyno pumps are reassembled in the reverse order of disassembly with special notes as outlined below:

1. Always replace all old washers, and packing. We also recommend replacing grease seals when new bearings are installed.
2. **Bearing Shaft Assembly** - When installing new bearings, make sure that they are seated against the shoulder on the shaft. Replace bearing lock washer and bearing lock nut. Tighten bearing lock nut securely.- Bend tab down onto lock nut to prevent loosening of nut. Make sure that the shaft collar, packing gland, and packing washer are installed on the drive shaft as the hollow end emerges in the bearing housing and approaches the stuffing box area. When replacing the bearing cover plate, tighten all cap screws evenly to prevent damage to the bearing cover plate and thrust grease seal.
3. **Do not over-lubricate bearings. (See Maintenance)**
3. When installing the connecting rod, make sure that the hole in the rod is aligned with the holes in the drive shaft and shaft collar **before** inserting the pin. Always use retaining nut washers. Insert pin, slip one retaining nut washer over each end of pin, attach nuts. Tighten nuts and slide shaft collar in to position to prevent nuts from turning. Tighten set screw in collar to **lock** it in place.
4. When replacing packing, insert one ring on the shaft, the lantern ring, and then three more rings. This will allow the lantern ring to line up with the grease fitting on the stuffing box. **Make sure you stagger the ends of the packing rings.** When installing the new packing, you may find that all but one ring will go on the drive shaft. When the pump has run for a short time and the new packing is compressed, this final ring can be installed.
5. When installing the stator on the rotor, it is best to lubricate the rotor with water (or a lubricant compatible with the rubber in the stator) to allow the stator to slip on easier. (Grease or oil is not compatible with type "R" or "B" stators.) When replacing the stator, always tighten it with the pipe wrench on the end of the stator nearest the suction housing. This will prevent it from binding and damaging the threads. If your stator has a stainless steel sleeve, use a teflon tape or similar material on the threads before replacing - on all stators with a carbon steel sleeve, use pipe dope.

6. **Caution: Dry operation is harmful to the pump. Always fill the pump with fluid to be handled prior to start up. Check any valves in discharge line to determine that no restrictions exist.**

MAINTENANCE

The Moyno pump has been designed for a minimum of maintenance, the extent of which is routine lubrication and adjustment of packing and infrequent lubrication of the bearings. The pump is one of the easiest to work on in that the main elements are very accessible and require few tools to disassemble.

Packing

The Moyno pump is normally furnished with die formed packing. The packing may be either grease lubricated through a grease fitting in the stuffing box or have plumbing connected to the housing to allow a water flush. (See Water Flush of Packing)

Packing gland adjusting nuts should be evenly adjusted so they are little more than finger tight. Over-tightening of the packing gland may result in premature packing failure and possible damage to the shaft and gland. When the packing is new, frequent minor adjustments are recommended for the first few hours of operation in order to compress and seat the packing. Greasing the packing often but with limited quantities of grease is the best practice. This can be done through a grease fitting which leads to a lantern ring in the mid-section of the packing. Do not use a one-piece spiral wrap of packing.

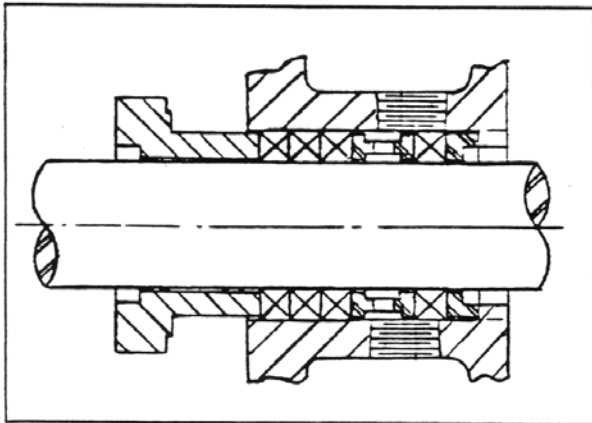

Cross section of stuffing box

Water Flush of Packing

When the material being pumped is abrasive in nature, it may be advantageous to flush the packing to prevent leakage under packing and excessive shaft wear.

Clean water can be injected through a 1/8" NPT tapped hole that normally houses the grease fitting for lubricating the packing. The water can be permitted to leak axially along the shaft in either direction or can be removed from the second tapped hole in the stuffing box. In both cases, the discharge from the stuffing box should be throttled slightly to maintain 10-15 PSI higher pressure in the stuffing box than is present in the suction housing.

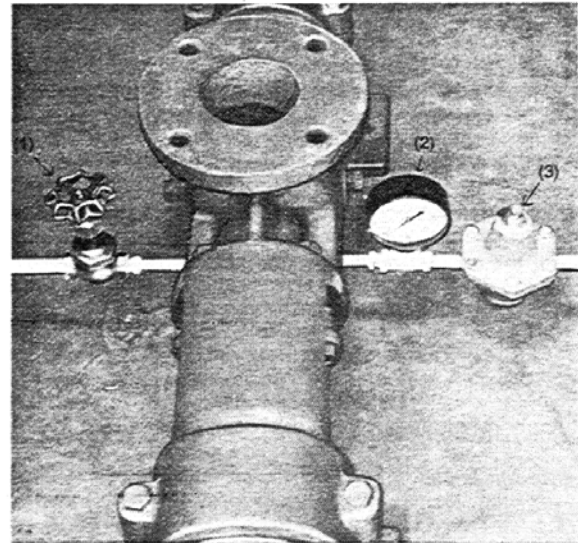

Typical water Flush to packing

This is a basic arrangement, other variations can be used.
(1) Throttling Valve (2) Pressure Gauge (3) Pressure Regulating Valve

Bearings

The Moyno pump is equipped with ball bearings in the drive end size L2 through L10. The bearings are lubricated at the factory and do not need additional lubrication for at least 1500 hours of normal operation.

When relubricating the bearings, the bearing-shaft assembly should be removed (See Disassembly instructions) and cleaned of old grease. Add only enough grease to fill the area between the bearings 1/3 full. Add a few drops of oil to bearing seals before reassembling. It is normal for bearings to run warm to the touch for the first few hours of operation.

Any type of Ep Lithium soap base grease is satisfactory for bearing lubrication. The use of Sodium or Calcium base grease is not recommended.

The following is a partial listing of approved bearing lubricants:

Dow Corning	DC 33
Keystone Lubricating Co.	Keystone #89
Texaco	Regal AFB2
Shell Oil Co.	Cyprina #3
Humble Oil & Refining Co.	Beacon 325
American Oil Co.	Supermil Grease #A72832
Mobil	EPI
Shell Oil Co.	Alvania #2

VARIATIONS OF STANDARD PARTS

ROTORS identified on parts listing are standard size with hard-chrome plated surface. Other variations of rotor size and finish may be ordered by selecting the standard rotor part number and changing the last digit of the rotor number as follows:

- 2 = Standard size, non-plated
- 3 = Undersize, chrome-plated
- 4 = Undersize, non-plated
- 5 = Oversize, chrome-plated

Do not change rotor sizes without consulting your local Moyno Sales Office. These variations are used for certain specialized pumping conditions only.

PACKING VARIATIONS listed are common to most type designations. Others may be specified by changing the last digit to the following:

- 1 = Standard on all type CDQ pumps
- 3 = Standard on all type CDR & SSR pumps
- 5 = Standard on all type SSQ pumps
- 7 = Optional--Solid Braided Teflon
- 8 = Optional--Teflon impregnated white asbestos

DRIVE SHAFTS shown have hard-chrome plating on the packing wear area. If non-plated drive shafts are required, select the standard part number and change the last digit to next higher number.

Example: B02261 to 802262.

L2 STANDARD HARDWARE		
ITEM	SIZE	# REQ.
Bearing Cover Plate Screw	3/4L X 1 /4D-20	4
Lock Washer		4
Stator & Pump Support Screw	1 3/4L X 3/8D-16	4
Set Screw on Shaft Collar	5/16L X 5/16D-18	1
Suction Housing Drain Plug	1/8D	3
Drain Plug on Stuffing Box	1/8D	1
Drain Plug at Bearing End	1/8D	1
Hex Key	5/32	1
Packing Gland Stud	1 1/2L X 5/160-18	2
Nut		2
Suction Housing Bolt	3/4L X 1/4D-20	4
Lock Washer		4

RECOMMENDED SPARE PARTS

The Moyno pump has been designed and built with all wearable parts replaceable. A recommended inventory of spare parts is dependent upon the application and importance of continued operation.

For the shortest possible downtime, we recommend the following parts be stocked:

- 1 - Rotor
- 1 - Stator
- 1 - Connecting Rod Kit

The above is only a suggested list. For further assistance in determining what you'll need for your application, contact your Moyno representative.