



Always the Right Solution™

SERVICE MANUAL

METERING/DOSING PUMP

CLOSE-COUPLED

B4015D, B4050D, B4100D, B4190D, B2400D, AND B4400D MODELS

DESIGN FEATURES

- Suction Housing: Stainless steel
Drive Adaptor - Gearmotor: Cast iron
Pump Rotor: Chrome plated, 300 series stainless steel
Pump Stator: Nitrile, EPDM, Fluoroelastomer
Seal: Single and double mechanical (carbon/ceramic), packing
Drive: Gear reducers with 120 MM flange, 1" shaft (Example SEW and Nord)

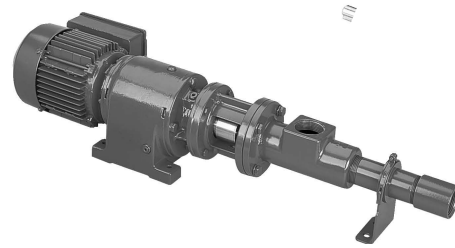

INSTALLATION

Mounting Position. Pump may be mounted in any position. When mounting vertically, it is necessary to keep motor above the seals to prevent possible seal leakage into motor.

Pre-Wetting. Prior to connecting pump, wet pump elements and mechanical seal by adding fluid to be pumped into suction and discharge ports.

Piping. Piping to pump should be self-supporting to avoid excessive strain on pump housings. The suction port is 1-1/2" NPT and the discharge port is 1-1/4" NPT. Use pipe "dope" or tape to facilitate disassembly and to provide seal on pipe connections.

Electrical. Follow the wiring diagram on the motor nameplate or inside the terminal box for the proper connections. The wiring should be direct and conform to local electrical codes. Check power connections for proper voltage. Voltage variations must not exceed ±10% of nameplate voltage. Motor is provided with internal automatic overload protection.

To prevent damage to pump, pump rotation must be clockwise when facing pump from motor end.

OPERATION

Self-Priming. With wetted pumping elements, the packed pump is capable of 25 feet of suction lift with pipe size equal to port size. Be sure suction lines are airtight or pump will not self-prime. Self-priming capabilities will vary due to fluid viscosity. Mechanical seal pump can suction lift to 15 feet.

DO NOT RUN DRY. Unit depends on liquid pumped for lubrication. For proper lubrication, flow rate should be at least 10% of rated capacity.

Storage. Always drain pump for extended storage periods by removing bottom drain plug in pump body.

Pressure Limits. See Table 1 for maximum discharge of each model.

Table 1

Table with 2 columns: Models, Max. Pressure. Rows include models 4015, 4050, 4100, 4190, 2400, and 4400 with their respective maximum pressures in PSI and bar.

Temperature Limits. Unit is capable for service at 10° F to 210°F with nitrile, 260°F with EPDM, and 350°F with fluoroelastomer. Note: an undersize rotor may be required for elevated temperature applications.

TROUBLESHOOTING

WARNING: Before making adjustments, disconnect power source and thoroughly bleed pressure from system prior to disassembly. Failure to do so could lead to electric shock or serious bodily harm.

Failure to Pump.

- 1. Motor will not start: Check power supply. Voltage must be ±10% of nameplate rating when motor is in locked rotor condition. Check for faulty capacitor on 1 phase models.
2. Motor runs and thermally kicks out: Check for excessive discharge pressure. Check for defective centrifugal switch on 1 phase models. Increase ventilation to motor. Do not use less than #14 wire size.

3. Stator torn; possible excessive pressure: Replace stator, check pressure at discharge port.
4. Flexible joint broken; possible excessive pressure: Replace joint, check pressure at discharge port.
5. Wrong rotation (3 phase only): Rotation must be clockwise when facing pump from motor end. Reverse the connections of any two line leads to the motor.

Pump Overloads.

1. Excessive discharge pressure. Check pressure at discharge port for maximum ratings given in Table 1.
2. Fluid viscosity too high: Limit fluid viscosity per "How to Select" calculations.

Noisy Operation.

1. Excessive suction lift or vacuum: Maximum suction lift is 25 feet for water.
2. Suction line too small: Check pipe size. Be sure lines are free from obstructions.
3. Pump Cavitates: At pump speed of 1725 rpm. Viscosity of fluid should not exceed 100 CP or 500 SSU.
4. Flexible joint worn: Replace joint. Check pressure at discharge port.
5. Insufficient mounting: Mount to a firm base. Vibration induced noise can be reduced by using mount pads and short sections of hose on suction and discharge ports.

Seal Leakage.

1. Leakage at startup: If leakage is slight, allow pump to run several hours to let faces run in.
2. Persistent seal leakage: Faces may be cracked from freezing or thermal shock. Replace seal.

Pump Will Not Prime.

1. Air leak on suction side: Check pipe connections.

PUMP DISASSEMBLY

WARNING: Before disassembling pump, disconnect power source and thoroughly bleed pressure from system. Failure to do so could result in electric shock or serious bodily harm.

1. Remove suction and discharge piping. Drain pump body by removing drain plug (261).
2. Remove discharge coupling (9) from stator (21).
3. Remove stator support clamp (40).
4. Remove stator (21) by unthreading from the suction housing (2). Lock rotor from turning by inserting a punch into the hole located in the center of the flexible joint (24). This will aid in removing the stator.
5. Remove the stator support retainer (39) if desired.
6. Remove the suction housing (2) by removing the screws (112) and lock washers (215).
7. Remove O-Ring (270) from the seal housing (3) (71) or the stuffing box (4). Inspect and replace if necessary.
8. Remove the rotor & shaft pins (46) from the flexible joint (24). Support the joint/rotor while removing with a small punch. These pins should not be reused. Replace with new pins upon reassembly.

9. Clean and inspect the flexible joint (24) looking for excessive play and breaks in the rubber boots. If sealing boots are damaged replace the flexible joint.
10. If packed model skip to **Step 14.**

Single Seal. Remove the mechanical seal (69) spring and spring retainer from the drive shaft assembly (26).

Double Seal. Remove seal housing (71) and O-ring (72), inspect, replace if necessary.

11. Remove the rotational portion of the mechanical seal from the drive shaft (26).
12. Remove the seal housing (3) or seal gland (73) from the drive adapter casting (1).
13. Remove the mechanical seal stationary from the seal housing (3) (71) and seal gland (73). Replace seal components if worn. Go to **Step 16.**
14. Remove the stuffing box (4) from the drive adapter casting (1).
15. Remove the packing gland halves (65) from the studs and remove the worn packing (72).
16. Remove the set screws (27) from the drive shaft assembly (26).
17. Remove the drive shaft assembly (26) from the motor/gearmotor shaft.
18. Remove the drive adapter casting from the motor/gearmotor. This completes the pump disassembly.

PUMP ASSEMBLY

1. Mount the drive adapter casting (1) to the motor/gearmotor, using appropriate hardware with the windows horizontal.
2. Slide the drive shaft assembly (26) onto the motor/gearmotor shaft, seating firmly against the shaft end.
3. Install the set screws (27) into the drive shaft assembly (26) locking the drive shaft assembly to the motor/gearmotor shaft.
4. On packed pump skip to **Step 5.**
 - Install the mechanical seal (69) (70) using the following procedure:
 - a. Clean and oil sealing faces using clean oil (not grease).
 - CAUTION: Do not use oil on EPDM parts. Substitute glycerin or soap and water.**
 - b. Oil outer surfaces of the seal seat, and push seat assembly into the seal housing (3) and seal gland on double seals.
 - c. Slide the seal housing (3) or seal gland (73) onto the drive shaft assembly (26) seating into the drive adapter (1).
 - d. After cleaning and oiling the shaft, slide the seal body along the drive shaft assembly (26) until it meets the seal seat.
 - e. Install the seal spring and spring retainer or second seal body on the shaft.
 - f. On double seal models, insert seal stationary into seal housing (71), mount O-ring (72) and slide onto shaft, enclosing the double seal.

5. On packed pumps perform the following:
 - a. Insert the packing rings (72) into the stuffing box alternating the joints 90°.
 - b. Install the packing gland halves (65) on the studs (70) without tightening on the packing.
 - c. Slide the stuffing box assembly onto the drive shaft assembly (26). Set the studs horizontal, seating the stuffing box into the drive adapter casting.
6. Insert the flexible joint (24) into the drive shaft assembly (26). Insert shaft pin (46) into the hole using a small punch. The seal spring will move to allow clearance for insertion. The spring retainer should rest against the flexible joint (24) after pin insertion.
7. Support flexible joint and insert rotor (22) aligning holes for insertion of rotor pin (46) using a small punch.
8. Insert O-Ring (270) into the groove in the seal housing (3) or stuffing box (4).
9. Install the drain plug (261) into suction housing (2) using pipe "dope" or sealing tape to ensure a leak-proof seal.
10. Attach the suction housing (2) to the drive adapter casting, using screws (112) and lockwashers (215). Note, a gap will remain between the suction housing and drive adapter casting.
11. Slide stator (21) onto rotor (22) using hand soap or equivalent as lubrication. Thread stator into suction housing (2) using pipe "dope" or sealing tape to ensure a leak-proof seal. To keep the rotor from turning, insert a punch into the hole in the flexible joint.
12. Slide stator support retainer ring (39) onto the stator.
13. Use the stator support clamp (40) to connect the stator support (38).
14. Thread discharge coupling (9) onto the stator (21) using pipe "dope" or sealing tape to ensure a leak-proof seal.
15. Lubricate rotor and stator by filling the suction housing with fluid to be pumped.
16. Firmly mount the pump. Connect suction and discharge piping and power source.

PARTS LIST

To determine part numbers for all parts, enter the table on the following page with the item number from the pump illustration below. Then locate the part number under the applicable model number. Notice the type column identifies the materials of construction. Parts listed with one part number for example are applicable to all models.

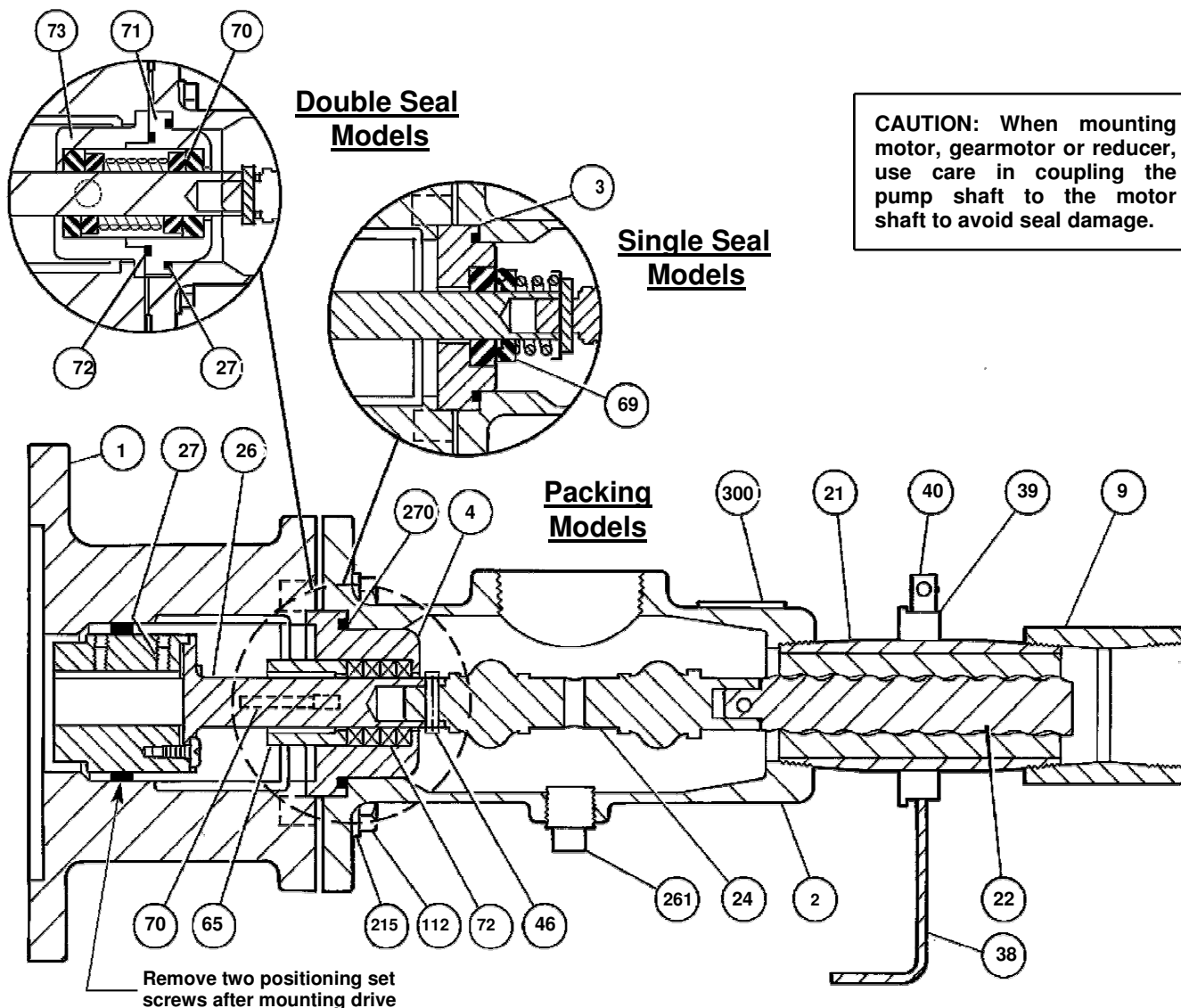

CLOSE COUPLED MODELS PARTS LIST

Item	Type	Description	Qty	B4015, B4050, B4100, B4190, B2400, B4400
1	CD	Drive Adapter - Gearmotor	1	3501688003
2	SS	Suction Housing	1	3403932007
3	SS	Seal Housing	1	3403930007
4	SS	Stuffing Box	1	3403934007
9	SS	Discharge Coupling	1	3205342020
21	See Table	Stator	1	See Stator Table
22	See Table	Rotor	1	See Rotor Table
24	Q,R,B,F	Flexible Joint	1	3308811005
26	SS	Drive Shaft Assembly	1	3403943003
27	SS	Set Screw	2	6060340040
38	SS	Stator Support	1	3403945001
39	SS	Stator Support Retainer	1	3201733000
40	SS	Clamp Assembly	1	3204277000 and 3201734000
46	SS	Rotor/Shaft Pin	2	3204069001
65	SS	Packing Gland Half	2	3403933007
69	Q,R,B,F	Mech Seal (Cbn vs Cer)	1	3206501000
69	Q,R,B,F	Mech Seal (AR)	1	3206503000
70	Q,R,B,F	Double Mechanical Seal	1	3208652002
71	SS	Seal Housing, Double	1	3403986015
72	SS	Packing Set	1	3403396002
72	Q,R,B,F	O-Ring	1	3207902128
73	SS	Seal Gland, Double	1	3403985015
111	SS	Packing Gland Stud	2	3208591000
112	SS	Screw	4	6191520141
215	SS	Lock Washer	4	6230010401
261	SS	Drain Plug	1	6100420030
270	Q,R	O-Ring	1	3207902134
270	B	O-Ring	1	3207904134
270	F	O-Ring	1	3207905134
300	SS	Name Plate	1	3208597000

Stator Material			
Element	Q (Nitrile)	B (EPDM)	F (Fluoro)
4015	3403923104	3403923304	3403923504
4050	3202145013	3203676013	3303719013
4100	3403924104	3403925304	3403924504
4190	3403925104	3403925304	3240392504
2400	4252489102	4252489302	4252489502
4400	4252489104	4252489304	4252489504

Rotor	
Element	300 Series Stainless Steel
4015	3403927015
4050	4252492015
4100	3403928015
4190	3403929015
2400	4252524015
4400	4252491015

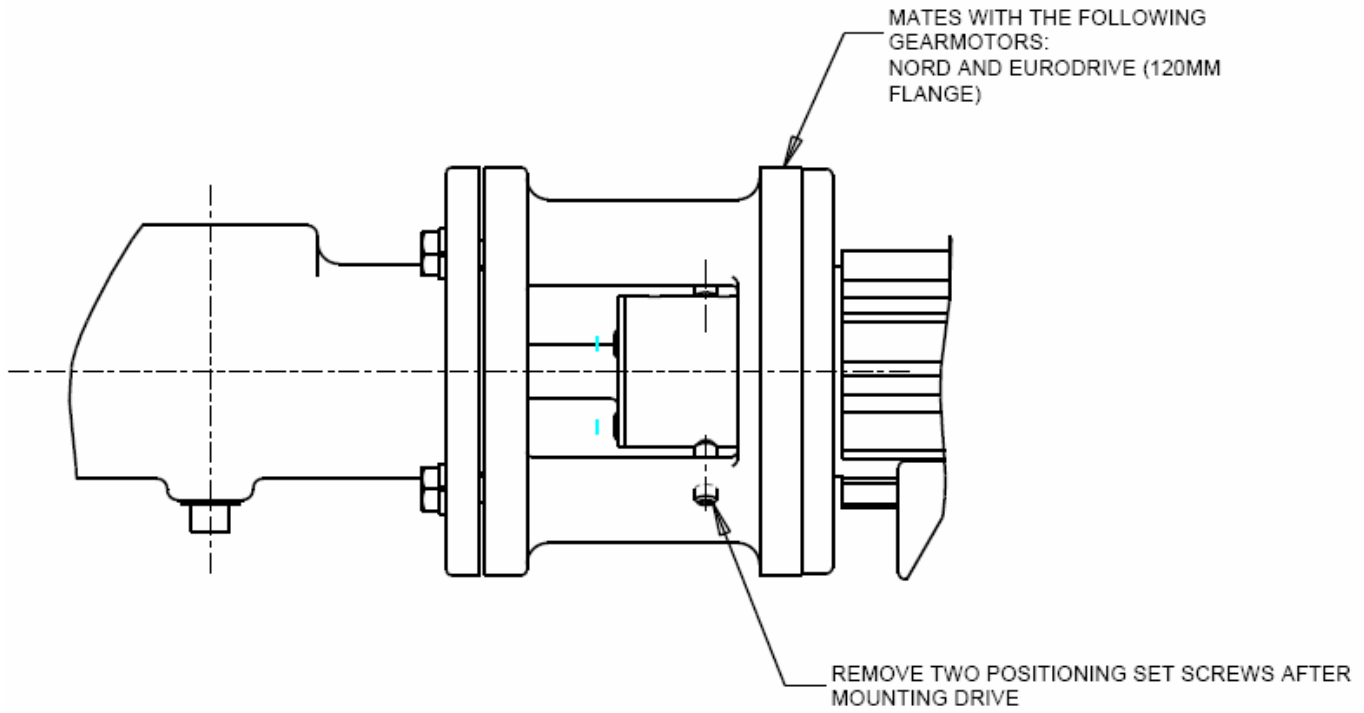

For further information, call:
Inside U.S.A. - 800-845-1310 or 800-325-1331
Outside U.S.A. - 937-327-3553