

SERVICE MANUAL

METERING/DOSING PUMP

MOTORIZED

**C4015E, C4100E, C4100F, C4190F, C4015G, C4100G, C4100H
C4190H, C4015J, C4100J, C4100K, and C4190K MODELS**

DESIGN FEATURES

Housing: Cast iron/Stainless steel

Pump Rotor: Chrome plated 416 and 316 stainless steel

Pump Stator: Nitrile, Natural Rubber, EPDM, Fluoroelastomer

Motor Shaft: AISI 416 stainless steel/ANSI 316 stainless steel

Seal: Mechanical (carbon/ceramic)

Flexible Joint: Prelubricated and sealed

Motor: 1 or 1/2 HP, 60 Hertz, 1725 rpm, totally enclosed, fan cooled (TEFC) C-Faced, 1 phase 115/230V or 3 phase 230/460V.

1 or 1/2 HP, 1725 rpm, totally enclosed fan cooled (TEFC) C-Faced, 90V. DC.

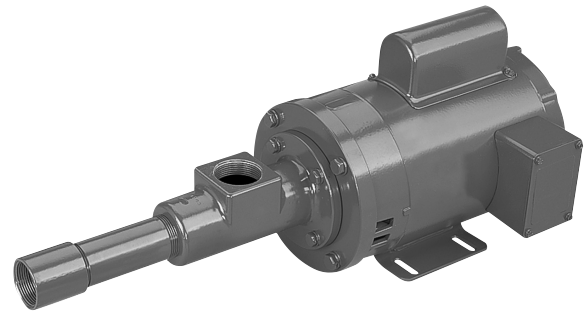

INSTALLATION

Mounting Position. Pump may be mounted in any position. When mounting vertically, it is necessary to keep motor above seals to prevent possible seal leakage into motor.

Pre-Wetting. Prior to connecting pump, wet pump elements and mechanical seal by adding fluid to be pumped into suction and discharge ports.

Piping. Piping to pump should be self-supporting to avoid excessive strain on pump housings. The suction port is 1-1/2" NPT and the discharge port is 1-1/4" NPT. Use pipe "dope" or tape to facilitate disassembly and to provide seal on pipe connections.

Electrical. Follow the wiring diagram on the motor nameplate or inside the terminal box for the proper connections. The wiring should be direct and conform to local electrical codes. Check power connections for proper voltage. Voltage variations must not exceed $\pm 10\%$ of nameplate voltage. Motor is provided with internal automatic overload protection.

Pump rotation should be clockwise when facing pump from motor end.

OPERATION

Self-Priming. With wetted pumping elements, the pump is capable of 25 feet of suction lift with pipe size equal to port size. Be sure suction lines are air tight or pump will not self prime. Self-priming capabilities will vary due to fluid viscosity.

DO NOT RUN DRY. Unit depends on liquid pumped for lubrication. For proper lubrication, flow rate should be at least 10% of rated capacity.

Storage. Always drain pump for extended storage periods by removing bottom drain plug in pump body.

Pressure Limits. See Table 1 for maximum discharge pressure of each model.

Table 1

Models 4015	Max. pressure 300 PSI, 20 bar
Models 4100	Max. pressure 300 PSI, 20 bar
Models 4190	Max. pressure 175 PSI, 12 bar

Temperature Limits. Unit is capable for service at 10°F to 210°F with nitrile, and to 260°F with EPDM, 185°F with natural rubber, and 350°F with fluoroelastomer. Note, an undersize rotor may be required for elevated temperature applications.

TROUBLESHOOTING

WARNING: Before making adjustments, disconnect power source and thoroughly bleed pressure from system prior to disassembly. Failure to do so could lead to electric shock or serious bodily harm.

Failure to Pump.

1. Motor will not start: Check power supply. Voltage must be $\pm 10\%$ of nameplate rating when motor is in locked rotor condition. Check for faulty capacitor on 1 phase models.
2. Motor runs and thermally kicks out: Check for excessive discharge pressure. Check for defective centrifugal switch on 1 phase models. Increase ventilation to motor. Do not use less than #14 wire size.
3. Stator torn; possible excessive pressure: Replace stator, check pressure at discharge port.
4. Flexible joint broken; possible excessive pressure: Replace joint, check pressure at discharge port.
5. Wrong rotation (3 phase only): Rotation must be clockwise when facing pump from motor end. Reverse the connections of any two line leads to the motor.
6. Excessive suction lift or vacuum.

Pump Overloads.

1. Excessive discharge pressure. Check pressure at discharge port for maximum ratings.
2. Fluid viscosity too high: Limit fluid viscosity per "How to Select" calculations.

Noisy Operation.

1. Excessive suction lift or vacuum: Maximum suction lift is 25 feet for water.
2. Suction line too small: Check pipe size. Be sure lines are free from obstructions.
3. Pump Cavitates: At pump speed of 1725 rpm. Viscosity of fluid should not exceed 100 CP or 500 SSU.
4. Flexible joint worn: Replace joint. Check pressure at discharge port.
5. Insufficient mounting: Mount to a firm base. Vibration induced noise can be reduced by using mount pads and short sections of hose on suction and discharge ports.

Seal Leakage.

1. Leakage at startup: If leakage is slight, allow pump to run several hours to let faces run in.
2. Persistent seal leakage: Faces may be cracked from freezing or thermal shock. Replace seal.

Pump Will Not Prime.

1. Air leak on suction side: Check pipe connections.

PUMP DISASSEMBLY

WARNING: Before disassembling pump, disconnect power source and thoroughly bleed pressure from system. Failure to do so could result in electric shock or serious bodily harm.

1. Remove suction and discharge piping. Drain pump body by removing drain plug (261).
2. Remove discharge coupling (9) from stator (21).
3. Remove stator (21) by unthreading from the suction housing (2). Lock rotor from turning by inserting a punch into the hole located in the center of the flexible joint (24). This will aid in removing the stator.
4. Remove the suction housing (2) by removing the screws (112) and lockwashers (215).
5. Remove O-Ring (270) from the seal housing adapter (3). Inspect and replace if necessary.
6. Remove the rotor and shaft pins (46) from the flexible joint (24). Support the joint/rotor while removing with a small punch. These pins should not be reused. Replace with new pins upon reassembly.
7. Clean and inspect the flexible joint (24) looking for excessive play and breaks in the rubber boots. If sealing boots are damaged replace the flexible joint.
8. Remove the mechanical seal (69) spring and spring retainer from the motor shaft. Remove the rotational portion of the mechanical seal from the motor shaft.
9. Remove the seal housing adapter (3) from the motor (1) by removing screws (220) and lockwashers (230) (not shown).
10. Remove the mechanical seal stationary from the seal housing adapter. This completes the pump disassembly.

PUMP ASSEMBLY

1. Install mechanical seal (69) in seal housing adapter using the following procedure:
 - a. Clean and oil sealing faces using clean oil (not grease).

CAUTION: Do not use oil on EPDM parts. Substitute glycerin or soap and water.

 - b. Oil outer surfaces of the seal seat, and push assembly over the motor shaft and into the seal housing adapter (3) seating it firmly and squarely.

- c. Mount the seal housing adapter (3) to the motor (1) ensuring that the drain slot is facing down. Use screws (220) and lockwashers (230).
- d. After cleaning and oiling the shaft, slide the seal body along the motor shaft until it meets the seal seat.
- e. Install seal spring and spring retainer on shaft.
2. Insert flexible joint (24) into motor shaft. Insert shaft pin (46) into hole using small punch. The seal spring will move to allow clearance for insertion. The spring retainer should rest against joint (24) after pin insertion.
3. Support flexible joint and insert rotor (22) aligning holes for insertion of rotor pin (46) using a small punch.
4. Insert O-Ring (270) into the groove in the seal housing adapter (3).
5. Install the drain plug (261) into suction housing (2) using pipe "dope" or sealing tape to provide a leak-proof seal.
6. Attach the suction housing (2) to the seal housing adapter (3) using screws (112) and lockwashers (215). Note, a gap will remain between the suction housing and seal housing adapter.
7. Slide stator (21) onto the rotor (22) using hand soap or equivalent as lubrication. Thread stator into suction housing (2) using pipe "dope" or sealing tape to ensure a leak-proof seal. To keep the rotor from turning, insert a punch into the hole in the flexible joint.
8. Thread discharge coupling (9) onto stator (21) using pipe "dope" or sealing tape to ensure a leak-proof seal.
9. Lubricate rotor and stator by filling suction housing and discharge housing with fluid to be pumped. Firmly mount the pump.
10. Connect suction and discharge piping and power source.

PARTS LIST

To determine part numbers for all parts enter the table on the following page with the item number from the pump illustration below. Then locate the part number under the applicable model number. Notice the type column identifies the materials of construction. Parts listed with one part number for example are applicable to all models.

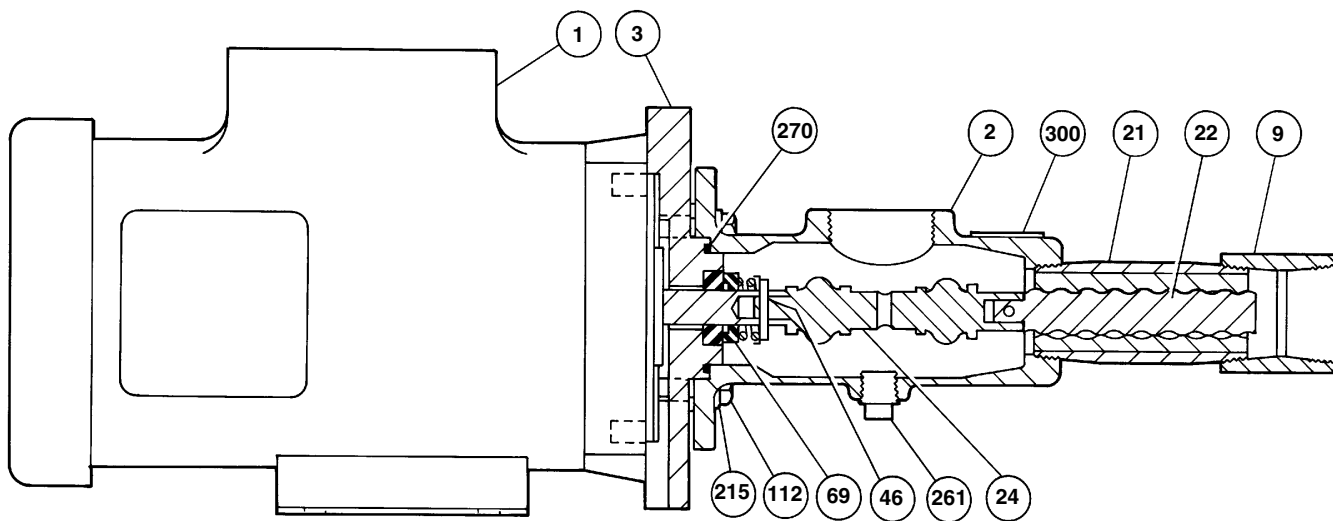

Not Shown	Qty.
220 Screw	4
230 Lockwasher	4

MOTORIZED MODELS PARTS LIST

PUMP MODELS															
Item	Type	Description	Req	C4015E	C4100E	C4100F	C4190F	C4015G	C4100G	C4100H	C4190H	C4015J	C4100J	C4100K	C4190K
1	CD	Motor	1	3403940000		3403940100		3304528100		3403941000		3403948000		3403948100	
1	SS	Motor	1	3403940003		3403940101		3304528103		3403941003		3403948001		3403948101	
2	CD	Suction Housing	1							3403932001					
2	SS	Suction Housing	1							3403932007					
3	CD	Seal Housing Adapter	1							3403937001					
3	SS	Seal Housing Adapter	1							3403937015					
9	CD	Discharge Coupling	1							3205341020					
9	SS	Discharge Coupling	1							3205342020					
21	Q	Stator	1	3403923104	3403924104	3403925104	3403923104	3403924104		3403925104	3403923104	3403924104		3403925104	
21	R	Stator	1	3403923204	3403924204	3403925204	3403923204	3403924204		3403925204	3403923204	3403924204		3403925204	
21	B	Stator	1	3403923304	3403924304	3403925304	3403923304	3403924304		3403925304	3403923304	3403924304		3403925304	
21	F	Stator	1	3403923504	3403924504	3403925504	3403923504	3403924504		3403925504	3403923504	3403924504		3403925504	
22	CD	Rotor	1	3403927007	3403928007	3403929007	3403927007	3403928007		3403929007	3403927007	3403928007		3403929007	
22	SS	Rotor	1	3403927015	3403928015	3403929015	3403927015	3403928015		3403929015	3403927015	3403928015		3403929015	
24	Q,R	Flexible Joint	1							3308811001					
24	B	Flexible Joint	1							3308811003					
24	F	Flexible Joint	1							3308811005					
46	CD/SS	Rotor Pin	1							3204069001					
46	CD/SS	Shaft Pin	1							3204069002					
69	Q,R	Mechanical Seal Std.	1							3202424000					
69	B	Mechanical Seal Std.	1							3206379000					
69	F	Mechanical Seal Std.	1							3206501000					
69	Q,R	Mechanical Seal AR	1							3206460000					
69	B	Mechanical Seal AR	1							3206502000					
69	F	Mechanical Seal AR	1							3206503000					
112	CD/SS	Screw	4							6191520141					
215	CD/SS	Lockwasher	4							6230010401					
220	CD/SS	Screw	4							6191530201					
230	CD/SS	Lockwasher	4							6230010411					
261	CD	Drain Plug	1							6100120031					
261	SS	Drain Plug	1							6100420030					
270	Q,R	O-Ring	1							3207902134					
270	B	O-Ring	1							3207904134					
270	F	O-Ring	1							3207905134					
300	CD/SS	Name Plate	1							3208597000					

**Note: For further information, call 800-845-1310 (Western USA)
800-325-1331 (Central & Eastern USA), or 937-327-3553 (Ohio)**