

# 2S-1 Simplex Plunger Pump

## Specifications

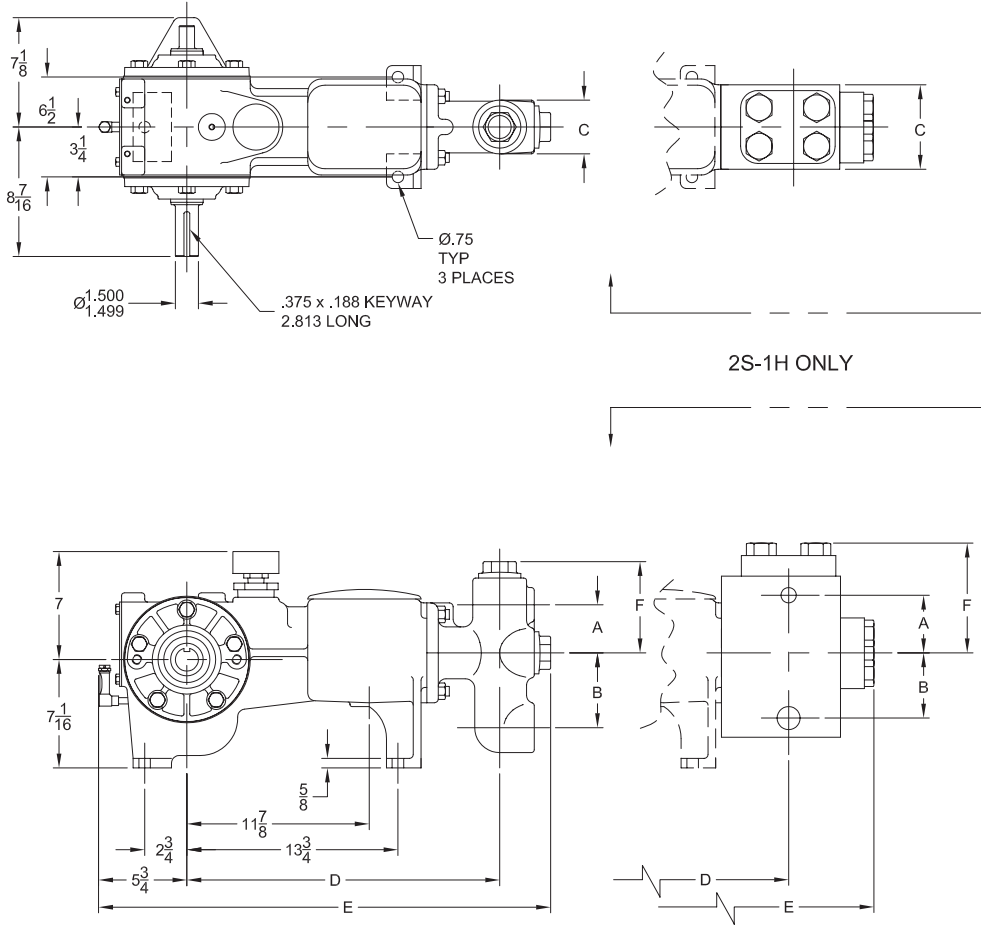

### Pump Size:

maximum plunger size x stroke length, in.(mm)  
2.000 x 1.000 (50.8 x 25.4)

### Rated BPH (kW) at 350 RPM

2.5 (1.9)

### Rated plunger load, pounds (kg)

2030 (921)

### Maximum discharge pressure: psi (kPa)

"L" model: 1149 (7920)

"M" model: 2042 (14081)

"H" model: 4595 (31681)

### Crankshaft extension:

Diameter, in.(mm): 1.500 (38.1)

Length, in.(mm): 3.375 (85.73)

Keyway width x depth, in.(mm):

3/8 x 3/16 (9.53 x 4.76)

Maximum recommended sheave diameter,

in.(mm): 25 (635)

For larger sizes: **Contact Factory**

### Oil Capacity, gallons (L)

Crankcase: 1/2 (1.89)

### Weight, pump only on

wood shipping skids, pounds (kg): 219 (99)

Weight varies with pump model

### Standard Materials for Fluid Ends:

"L" & "M" models

Cast Ductile Iron, Cast 316 Stainless Steel

Cast Nickel-Aluminum-Bronze

Plate Carbon Steel

"H" model

Forged/Plate Carbon Steel

Forged 15-5 Stainless Steel

Pump Model	Flange Connections		Dimensions (Inches)					
	Discharge Connection Sizes	Suction Connection Sizes	A	B	C	D	E	F
2S-1L	1 (25.4)-11 1/2 FNPT	2 (50.8)-11 1/2 FNPT	3 1/8	4 7/8	3 1/2	20 3/8	29 9/16	5 15/16
2S-1M	1 (25.4)-11 1/2 FNPT	2 (50.8)-11 1/2 FNPT	3 1/8	4 7/8	3 1/2	20 3/8	29 9/16	5 15/16
2S-1H	3/4 (19.05)-14 FNPT	1 1/4 (31.75)-11 1/2 FNPT	3 3/4	4 1/4	5 1/2	20	31 5/16	7 1/8

# 2S-1 Simplex Plunger Pump

## Performance Data

PUMP	English Units					50 RPM		150 RPM		200 RPM		250 RPM		300 RPM		350 RPM	
	Plunger Dia. In.	Plunger Area Sq. In.	BPD per RPM	GPM per RPM	Max. Press. PSI	BPD	GPM	BPD	GPM	BPD	GPM	BPD	GPM	BPD	GPM	BPD	GPM
2S-1L (P50BLS)	2.000	3.1416	0.4663	0.0136	646	24	0.7	70	2.0	94	2.7	117	3.4	140	4.1	164	4.8
	1.875	2.7612	0.4098	0.0120	735	21	0.6	62	1.8	82	2.4	103	3.0	123	3.6	144	4.2
	1.750	2.4053	0.3570	0.0104	844	18	0.5	54	1.6	72	2.1	90	2.6	108	3.1	125	3.6
	1.625	2.0739	0.3078	0.0090	979	16	0.4	47	1.3	62	1.8	77	2.2	93	2.7	108	3.1
	1.500	1.7671	0.2623	0.0076	1149	14	0.4	40	1.1	53	1.5	66	1.9	79	2.3	92	2.7
2S-1M (P50B)	1.750	2.4053	0.3570	0.0104	844	18	0.5	54	1.6	72	2.1	90	2.6	108	3.1	125	3.6
	1.625	2.0739	0.3078	0.0090	979	16	0.4	47	1.3	62	1.8	77	2.2	93	2.7	108	3.1
	1.500	1.7671	0.2623	0.0076	1149	14	0.4	40	1.1	53	1.5	66	1.9	79	2.3	92	2.7
	1.375	1.4849	0.2204	0.0064	1367	12	0.3	34	1.0	45	1.3	56	1.6	67	1.9	78	2.2
	1.250	1.2272	0.1821	0.0053	1654	10	0.3	28	0.8	37	1.1	46	1.3	55	1.6	64	1.9
2S-1H (P50BH)	1.000	0.7854	0.1166	0.0034	2585	6	0.2	18	0.5	24	0.7	30	0.8	35	1.0	41	1.2
	0.875	0.6013	0.0892	0.0026	3376	5	0.1	14	0.4	18	0.5	23	0.7	27	0.8	32	0.9
	0.750	0.4418	0.0656	0.0019	4595	4	0.1	10	0.3	14	0.4	17	0.5	20	0.6	23	0.7
Brake Horsepower Required						0.4		1.1		2.0		1.8		2.1		2.5	

PUMP	Metric Units					50 RPM		150 RPM		200 RPM		250 RPM		300 RPM		350 RPM	
	Plunger Dia. mm	Plunger Area cm <sup>2</sup>	M <sup>3</sup> /Hr per RPM	L/Sec. per RPM	Max. Press. kPa	M <sup>3</sup> /Hr	L/Sec.	M <sup>3</sup> /Hr	L/Sec.	M <sup>3</sup> /Hr	L/Sec.	M <sup>3</sup> /Hr	L/Sec.	M <sup>3</sup> /Hr	L/Sec.	M <sup>3</sup> /Hr	L/Sec.
2S-1L (P50BLS)	51	20.268	0.0031	0.0009	4455	0.15	0.04	0.46	0.13	0.62	0.17	0.77	0.21	0.93	0.26	1.08	0.30
	48	17.814	0.0027	0.0008	5069	0.14	0.04	0.41	0.11	0.54	0.15	0.68	0.19	0.81	0.23	0.95	0.26
	44	15.518	0.0024	0.0007	5819	0.12	0.03	0.35	0.10	0.47	0.13	0.59	0.16	0.71	0.20	0.83	0.23
	41	13.380	0.0020	0.0006	6749	0.10	0.03	0.31	0.08	0.41	0.11	0.51	0.14	0.61	0.17	0.71	0.20
2S-1M (P50B)	38	11.401	0.0017	0.0005	7920	0.09	0.02	0.26	0.07	0.35	0.10	0.43	0.12	0.52	0.14	0.61	0.17
	44	15.518	0.0024	0.0007	5819	0.12	0.03	0.35	0.10	0.47	0.13	0.59	0.16	0.71	0.20	0.83	0.23
	41	13.380	0.0020	0.0006	6749	0.10	0.03	0.31	0.08	0.41	0.11	0.51	0.14	0.61	0.17	0.71	0.20
	38	11.401	0.0017	0.0005	7920	0.09	0.02	0.26	0.07	0.35	0.10	0.43	0.12	0.52	0.14	0.61	0.17
	35	9.580	0.0015	0.0004	9426	0.07	0.02	0.22	0.06	0.29	0.08	0.36	0.10	0.44	0.12	0.51	0.14
2S-1H (P50BH)	32	7.917	0.0012	0.0003	11405	0.06	0.02	0.18	0.05	0.24	0.07	0.30	0.08	0.36	0.10	0.42	0.12
	29	6.413	0.0010	0.0003	14081	0.05	0.01	0.15	0.04	0.20	0.05	0.24	0.07	0.29	0.08	0.34	0.10
	25	5.067	0.0008	0.0002	17821	0.04	0.01	0.12	0.03	0.15	0.04	0.19	0.05	0.23	0.06	0.27	0.08
2S-1H (P50BH)	22	3.879	0.0006	0.0002	23276	0.03	0.01	0.09	0.02	0.12	0.03	0.15	0.04	0.18	0.05	0.21	0.06
	19	2.850	0.0004	0.0001	31681	0.02	0.01	0.07	0.02	0.09	0.02	0.11	0.03	0.13	0.04	0.15	0.04
Kilowatts Required						0.3		0.8		1.5		1.3		1.6		1.9	

For operation below 50 RPM, an auxiliary lubrication system is required.

Volumetric Rate is based on 100% Volumetric Efficiency. Brake Horsepower/Kilowatts Required is based on 72% Mechanical Efficiency.

The information and data on this sheet is accurate to the best of our knowledge and belief, but are intended for general information only. Applications suggested for the materials are described only to help readers make their own evaluations and decisions, and are neither guarantees nor to be construed as express or implied warranties of suitability for these or other applications. National Oilwell makes no warranty either express or implied beyond that stipulated in National Oilwell Standard Terms and Conditions of Sale.

Authorized Distributor:



www.nov.com • mission.sales@nov.com  
 10000 Richmond, Houston, Texas 77042  
 (713)346-7500 (phone) • (713)346-7366 (fax)