

31Q-2 Quintuplex Plunger Pump

Specifications

Pump Size:

maximum plunger size x stroke length, in.(mm):
1.750 x 2.250 (44.5 x 57.15)

Rated BHP (kW) at 490 RPM: 31 (23)

Rated plunger load, pounds (kg): 2030 (921)

Maximum discharge pressure: psi (kPa)

"L" model: 2042 (14081)

Crankshaft extension:

Diameter, in.(mm): 2.125 (53.98)

Length, in.(mm): 4.31 (109.5)

Keyway width x depth, in.(mm):

1/2 x 1/4 (12.7 x 6.35)

Maximum recommended sheave diameter,
in.(mm): 33.5 (850.9)

For larger sizes: **Contact Factory**

Oil Capacity, gallons (L)

Crankcase: 2 (7.57)

Weight, pump only on

wood shipping skids, pounds (kg)

"L" model: 658 (298)

Standard Materials for Fluid Ends:

"L" model

Cast Ductile Iron

Cast Nickel-Aluminum-Bronze

Cast Duplex Stainless Steel

Forged/Plate Carbon Steel

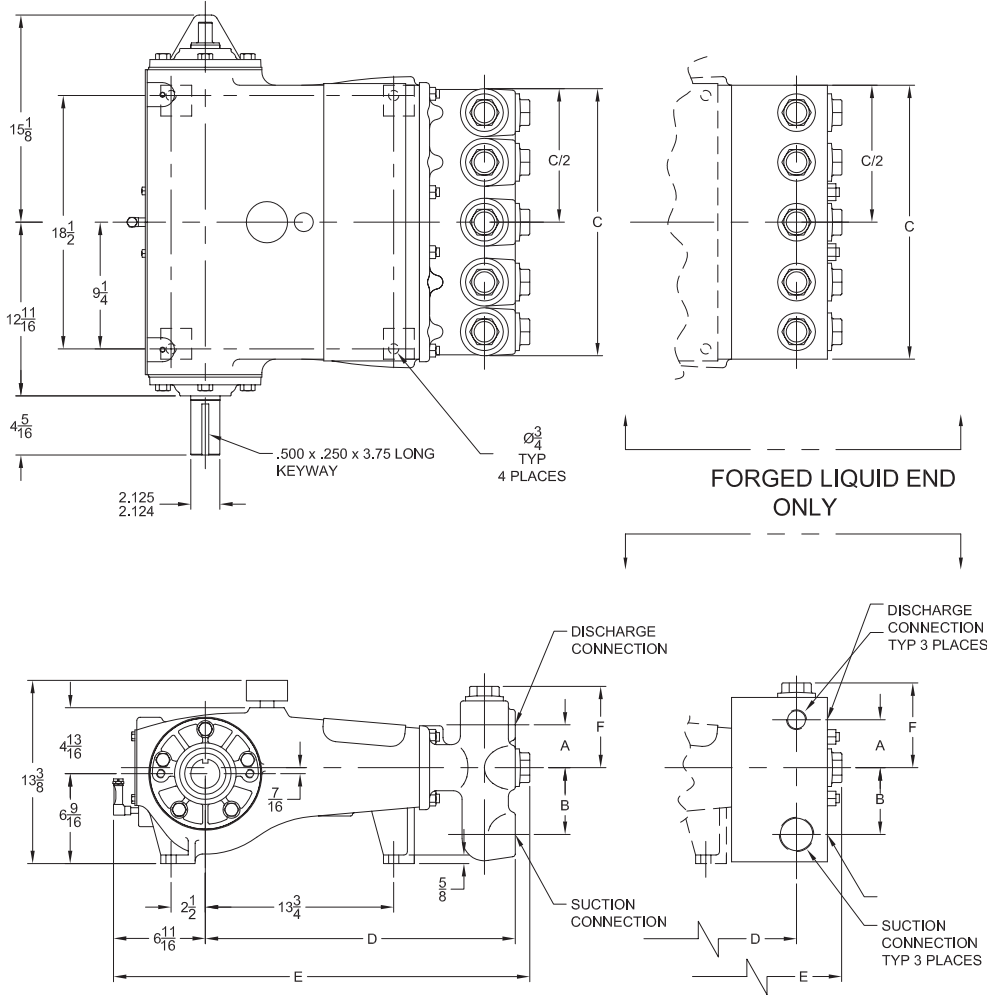

Pump Model	Flange Connections		Dimensions (Inches)					
	Discharge Connection Sizes	Suction Connection Sizes	A	B	C	D	E	F
Cast F.E.	1 (25.4)-11 1/2 FNPT	2 (50.8)-11 1/2 FNPT	3 3/8	4 7/8	19 1/2	22 5/8	30 3/8	5 5/16
Forged F.E.	1 (25.4)-11 1/2 FNPT	2 (50.8)-11 1/2 FNPT	3 1/2	4 7/8	20	20 3/8	30 3/8	6 3/16

31Q-2 Quintuplex Plunger Pump

Performance Data

PUMP	English Units					50 RPM		150 RPM		250 RPM		350 RPM		400 RPM		490 RPM	
	Plunger Dia. In.	Plunger Area Sq. In.	BPD per RPM	GPM per RPM	Max. Press. PSI	BPD	GPM	BPD	GPM	BPD	GPM	BPD	GPM	BPD	GPM	BPD	GPM
31Q-2L	1.750	2.4053	4.0162	0.1171	844	201	5.86	603	17.6	1005	29.3	1406	41.0	1607	46.9	1968	57.4
(5P200A)	1.625	2.0739	3.4630	0.1010	979	174	5.05	520	15.2	866	25.3	1213	35.4	1386	40.4	1697	49.5
	1.500	1.7671	2.9507	0.0861	1149	148	4.30	443	12.9	738	21.5	1033	30.1	1181	34.4	1446	42.2
	1.375	1.4849	2.4794	0.0723	1367	124	3.62	372	10.8	620	18.1	868	25.3	992	28.9	1215	35.4
	1.250	1.2272	2.0491	0.0598	1654	103	2.99	308	8.96	513	14.9	718	20.9	820	23.9	1005	29.3
	1.125	0.9940	1.6598	0.0484	2042	83	2.42	249	7.26	415	12.1	581	16.9	664	19.4	814	23.7
	Brake Horsepower Required					4		10		17		22		26		31	

PUMP	Metric Units					50 RPM		150 RPM		250 RPM		350 RPM		400 RPM		490 RPM	
	Plunger Dia. cm	Plunger Area cm ²	M ³ /Hr per RPM	L/Sec. per RPM	Max. Press. kPa	M ³ /Hr	L/Sec.	M ³ /Hr	L/Sec.	M ³ /Hr	L/Sec.	M ³ /Hr	L/Sec.	M ³ /Hr	L/Sec.	M ³ /Hr	L/Sec.
31Q-2L	44	15.518	0.0266	0.0074	5819	1.33	0.37	3.99	1.11	6.65	1.85	9.31	2.59	10.64	2.96	13.04	3.62
(5P200A)	41	13.380	0.0229	0.0064	6749	1.15	0.32	3.44	0.96	5.73	1.59	8.03	2.23	9.18	2.55	11.24	3.12
	38	11.401	0.0195	0.0054	7920	0.98	0.27	2.93	0.81	4.89	1.36	6.84	1.90	7.82	2.17	9.58	2.66
	35	9.580	0.0164	0.0046	9426	0.82	0.23	2.46	0.68	4.11	1.14	5.75	1.60	6.57	1.82	8.05	2.24
	32	7.917	0.0136	0.0038	11405	0.68	0.19	2.04	0.57	3.39	0.94	4.75	1.32	5.43	1.51	6.65	1.85
	29	6.413	0.0110	0.0031	14081	0.55	0.15	1.65	0.46	2.75	0.76	3.85	1.07	4.40	1.22	5.39	1.50
	Kilowatts Required					3.0		7.5		13		17		19		23	

For operation below 75 RPM, an auxiliary lubrication system is required.

Volumetric Rate is based on 100% Volumetric Efficiency. Brake Horsepower/Kilowatts Required is based on 90% Mechanical Efficiency.

The information and data on this sheet is accurate to the best of our knowledge and belief, but are intended for general information only. Applications suggested for the materials are described only to help readers make their own evaluations and decisions, and are neither guarantees nor to be construed as express or implied warranties of suitability for these or other applications. National Oilwell makes no warranty either express or implied beyond that stipulated in National Oilwell Standard Terms and Conditions of Sale.

Authorized Distributor:



www.nov.com • mission.sales@nov.com
 10000 Richmond, Houston, Texas 77042
 (713)346-7500 (phone) • (713)346-7366 (fax)